

System One

by VALET®

HOME COMMUNICATION EQUIPMENT

OWNERS MANUAL

REV 2

TABLE OF CONTENTS

INTRODUCTION.....	2
Features Include	
PARTS IDENTIFICATION.....	3
POWERING UP THE SYSTEM.....	3
MODE DEFINITIONS.....	4
Music Mode	
Monitor Mode	
Privacy Mode	
PAGING CALLS.....	6
SELECT CALLS.....	7
DOOR/GATE STATION OPERATION.....	8
AUXILIARY/LOCK OUTPUT.....	9
FUNCTIONS OF KEYS AND CONTROLS.....	9
Local Volume Control	
Auxiliary Input Jack – Type B	
PROGRAMMING OPTIONS.....	10
Program Mode	
6 Wire / 8 Wire Mode	
Single Digit and Double Digit Select Calling	
Keypad Backlighting	
Changing Room Station Coding	
TROUBLESHOOTING.....	12
TECHNICAL SPECIFICATIONS.....	13

INTRODUCTION

The SYSTEM ONE Home Communication System provides the simplicity and reliability of digital technology and can be installed using up to 20 stations offering great flexibility and convenience.

FEATURES INCLUDE:

- Paging and Select call capability so you can target your calls to individual stations, groups or stations or the entire system
- Hands free reply to all calls; especially helpful with young children who can reply from any part of a room without the need to press a button
- Privacy function to avoid being listened to by other stations
- Multiple Door/Gate release (Optional)
- Automatic reset circuitry so you do not have to remember to reset any switches after making and intercom call
- Switchable keypad back lighting at all room stations

This total Home Communications System continues to set the highest standards of quality and performance for which Valet® is well known.

To assist in the initial understanding of the operation of this system, we recommend you follow the order in which the instructions are set out.

System One offers the flexibility of installation without a Master station. For information on installation of systems with Masters please refer to the Master Supplement.

PARTS IDENTIFICATION

Door Station

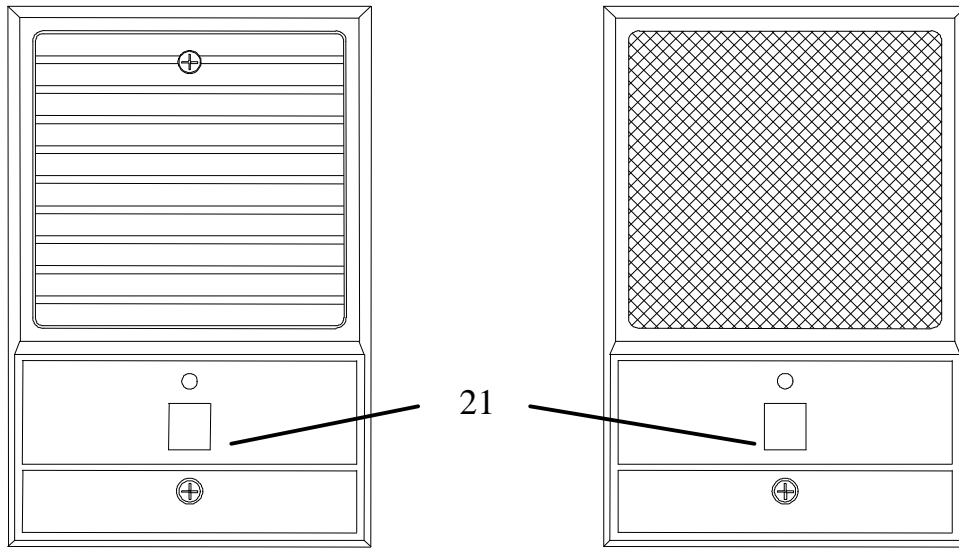

Louvered Door Station

Decor Door Station

Room Station

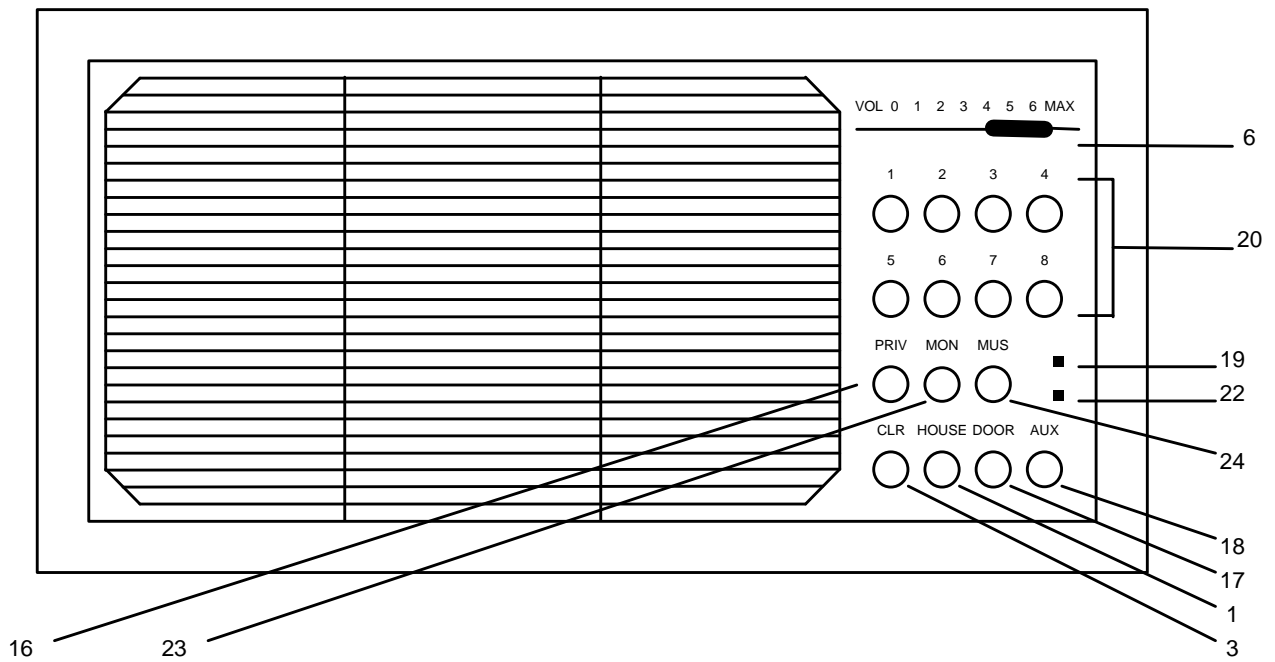

POWERING UP THE SYSTEM

18/2 cable should be connected from the transformer to the DC power booster, this distance should not exceed 16 feet. The DC power booster unit should be connected directly to the systems most central room station. Cable for this connection is provided on the DC power booster unit.

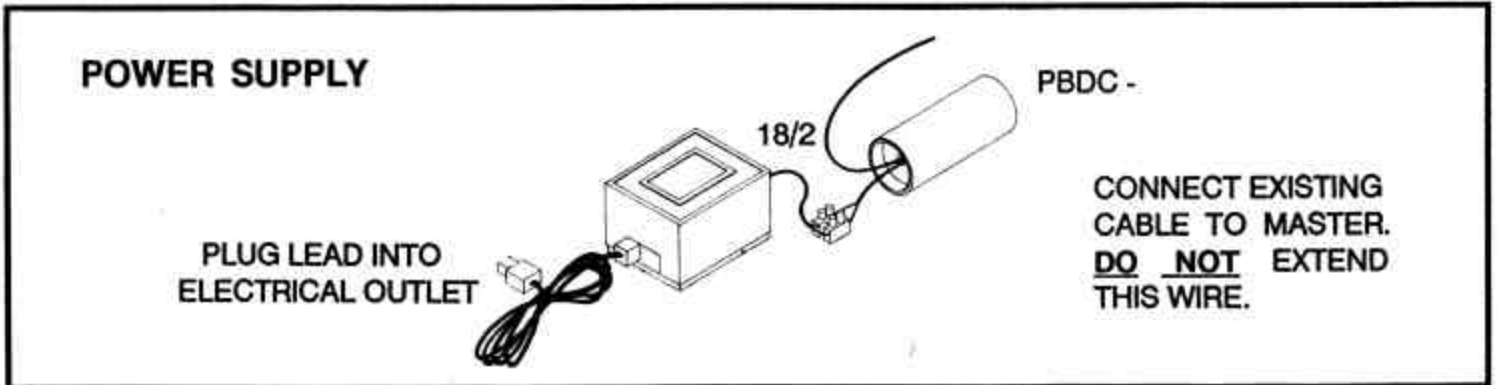

MODE DEFINITIONS

System one allows you to choose or alter settings at individual stations. To gain the greatest benefit from your system, we strongly recommend you carefully read what settings are available and how you can use them to your advantage.

Music Mode

Any station set to this mode can listen to any other station being monitored, and can listen to music from the master or auxiliary input jack where these have been fitted.

To select Music Mode:

- Press the 'MUSIC' key **24** at the station where this function is required (Red light will come on indicating station is in Music Mode)
- Ensure 'LOCAL VOLUME CONTROL' **6** is set to a reasonable level

To de-select Music Mode:

- Press the 'MUSIC' key **24** (Red light will turn off indicating station is no longer in Music Mode)

Monitor Mode

Any station set to this mode can be listened to by other stations for example;

To ensure that a baby is sleeping soundly or that a sick child or an elderly parent is comfortable at night.

To select Monitor Mode:

- Press the 'MONITOR' key **23**
(The green light will come on indicating the microphone is activated)

- NOTE:**
- Any station desiring to listen to a monitored station should be set to Music Mode - See above
 - Listening to monitored stations is more effective if the radio is turned off at the master **
 - Any station set to monitor mode **will not respond** to paging calls, door calls and door chimes but **will respond** to select calls which allows for communication to the station being monitored

To de-select Monitor Mode:

- Press the 'MONITOR' key **23**
The green light will turn off indicating the microphone is de-activated

Privacy Mode

This mode caters for situations where you want to prevent other stations from listening in to a particular room by disabling the station's ability to reply to incoming calls.

To engage Privacy Mode:

- Press the 'PRIVACY' key **16** at the station where this mode of operation is required
(The green light will flash indicating the station is in Privacy Mode)

To disengage Privacy Mode:

- Press the 'Privacy' key **16**
(The green light will stop flashing indicating the station is no longer in Privacy Mode)

- NOTE:**
- Outgoing calls can be made while in Privacy Mode
 - Music, Monitor and Privacy Modes reset on power up and therefore also reset in the event of a power disruption.
This can be overcome if an optional standby battery is used in conjunction with the power supply. (Consult your Local Distributor for further information)

PAGING CALLS

A Paging Call communicates to all other stations with the exception of door stations and is the best method of speaking to someone if your not exactly sure where they are.

To page all stations:

- Press and hold the 'HOUSE' key **1** at master or any room station
- The green light will turn on indicating your microphone is active
- Commence your conversation then release the 'HOUSE' key **1** to listen for a reply
- The green light will turn off at the station initiating the call and will turn on at all receiving stations enabling the person(s) receiving the call to reply
* Those replying to a call need not press any buttons. All replies are 'hands free'
- Continue the conversation pressing the 'HOUSE' key **1** to talk and releasing the 'House' key **1** to listen
- When the conversation is complete the system will reset after approximately 20 seconds from when the 'HOUSE' key was last released **or** the system can be reset manually by pressing the 'CANCEL / CLEAR' key **3**

Important Exceptions

- Stations set to Monitor MODE or with volume control turned to minimum will not receive Paging calls
- Stations set to PRIVACY MODE will not allow a 'hands free reply'
- Do not initiate a call if the red light is flashing as this indicates that someone is already using the system to communicate

SELECT CALLS

A Select Call directs communication to a particular station or group of stations within the system with the exception of door stations.

If your system has been programmed for double digit format to allow for more than eight Select Call channels, refer to section “Initiating a Select Call – Double Digit Format” below.

Initiating a Select Call - Single Digit Format:

- Press and hold the selection number (1-8) on the dialing keypad **20** at the master or any room station
- The green light will turn on indicating your microphone is active
- Commence your conversation then release the key to listen for a reply
- The green light will turn off at the initiating station and will turn on at the receiving station(s) enabling the person(s) receiving the call to reply
 - * Those replying to a call need not press any buttons. All replies are ‘hands free’
- Continue the conversation by pressing the selected number to talk and releasing the selected number to listen
- When the conversation is complete the system will reset after approximately 20 seconds from when the selected number was last released **or** the system can be reset manually by pressing the ‘CANCEL / CLEAR’ key **3**

Initiating a Select Call - Double Digit Format:

- Press the first digit of the selection number (1-3) on the dialing keypad **20** at any room station
- The red light will begin flashing
- Press and hold the second digit of the selection number (1-8) on the dialing keypad
- The green light will turn on indicating your microphone is active
- Commence your conversation then release the second digit key to listen for a reply
- The green light will turn off at the initiating station and will turn on at the receiving station(s) enabling the person(s) receiving the call to reply
 - * Those replying to a call need not press any buttons. All replies are ‘hands free’
- Continue the conversation by pressing the second digit key to talk and releasing the second digit key to listen
- When the conversation is complete the system will reset after approximately 20 seconds from when the second digit key was last released **or** the system can be reset manually by pressing the ‘CANCEL / CLEAR’ key **3**

Important Exceptions

- Stations with volume controls turned to minimum will not receive any calls
- Stations set to PRIVACY MODE will not allow a 'hands free reply'
- Do not initiate a call if the red light is flashing as this indicates that someone is already using the system to communicate

DOOR/GATE STATION OPERATION

How to talk to door/gate stations:

A visitor activating the Front Door/Gate Button **21** activates an electronic door chime that rings at all stations providing local volume controls are not turned to minimum and the stations are not set to Monitor mode.

To talk to a visitor at the Front Door or Gate

- Press and hold the 'DOOR' key **17** at the master or at any room station
- The green light will come on
- Commence the conversation and release the 'DOOR' button to listen to reply
- The green light turns off
- The visitor does not have to press anything.....just talk
- Continue the conversation pressing the 'Door' key to talk and releasing the 'DOOR' key to listen
- When the conversation is complete the system will reset after approximately 20 seconds from when the 'Door' key **17** was last released **or** the system can be reset manually by pressing the 'CANCEL / CLEAR' key **3**

Important Exception

- Stations set to Monitor MODE or with volume control turned to minimum will not hear the electronic chime when a visitor presses the Front Door/Gate button **21**

AUXILIARY/LOCK OUTPUT

Electronic door locks, Automatic gates, Courtesy lights, Alarm panic circuits, etc. can be controlled from the master or any room station if optional auxiliary output boards have been fitted to your system.

These outputs can be programmed to time out or toggle depending on the application.

To activate an output:

- Press and release the 'AUXILIARY OUTPUT' key **18** at master or any room station followed by the predetermined number on the 'DIALLING KEYPAD' **20** for the device you wish to control
- If the output is programmed to time out the device will de-activate or reset after a predetermined period of time
- If the output is programmed to toggle the output will remain on until the 'AUXILIARY OUTPUT' key **18** followed the predetermined number on the 'DIALLING KEYPAD' **20** are pressed again

NOTE: For this Optional feature to be available the fitting of Auxiliary output boards and additional wiring are required at installation.

FUNCTIONS OF KEYS AND CONTROLS

Local Volume Controls **6**

Adjustment of this control will set the speaker volume at the particular station for:

- a) Music
 - b) Communication
 - c) Electronic Chime
- Slide the control to the desired level
(Usual setting is about 3/4)

Auxiliary Input Jack - Type **B**

Optional accessory allowing an external audio device to be connected to the intercom system where a master has not been incorporated.

Note: A suitable connecting lead is required to connect the external audio device to either of the input jacks above.

PROGRAMMING OPTIONS (System One w/VR102 Board Only)

In Program mode System One room stations can have the following options programmed:

- 6 Wire or 8 Wire operation (Installer option)
- Single digit or double digit operation for Select Calls (Installer option)
- Keypad back lighting - on or off (User option)
- Station coding (User option)

Enter Program mode

Enter programming mode by pressing the “PRIVACY” and “MONITOR” buttons simultaneously.

6 Wire / 8 Wire Mode

This setting is determined by how the system has been wired.

- Green LED **off** indicates 6 Wire and Green LED **on** indicates 8 Wire
- Pressing house button toggles between 6 Wire and 8 wire modes

NOTE: This setting is usually set by the installer and should not be altered.

Single digit and Double digit Select Calling

Single digit Select Calling is designed for systems requiring up to 8 select call channels.

Double digit Select Calling is designed for systems requiring from 9 to 20 select call channels.

- Single digit numbers are displayed as a series of 1 to 8 repeated flashes
- Double digit numbers are displayed by 2 quick flashes (indicating Double digit mode) followed by 1 to 3 flashes (indicating the first digit) followed by 1 to 8 flashes (indicating the second digit)
- The Auxiliary button is used to toggle between Single Digit & Double Digit modes

NOTE: This setting is usually set by the installer and generally should not be altered.

Keypad Backlighting

Keypad illumination can be toggled on or off using the Door button.

Changing Room Station Coding

For the purpose of Select Calling (Calling individual or grouped stations) each station must be allocated a number between 1 and 8 (Single digit) or 11 and 38 (Double digit). If more than one station is allocated the same number, the stations having the same number will form a group.

Allocating a number to a station, is done by means of programming via the keypad.

Single Digit

- Enter a number between 1 and 8 by pressing the corresponding button
- The Red LED will repeatedly flash the programmed number while in program mode

Double Digit

- Enter a number in the ranges of 11 to 18, 21 to 28 or 31 to 38
- The Red Led will quickly flash twice, then flash the first digit and then flash the second digit.
- This sequence will continue to flash while in program mode

Exit Program Mode

- Exit program mode by pressing the "CLEAR" button

TROUBLE SHOOTING

Because System One automatically resets at the completion of all intercom call functions, there are few areas, once installation and testing has been completed and the instructions read, that should cause you any problems. In this manual there are various NOTES and IMPORTANT EXCEPTIONS at the completion of certain sections detailing why some functions are not available. Should you find you are having problems in any intercom area we suggest that you return to the applicable section and check the notes and exceptions listed.

Listed below are some of the most common problems and their solutions.

NO OPERATION FROM SYSTEM AT ALL

Ensure three-pin plug from power supply is properly plugged in and power point is turned on.

Experience shows that most service problems relate either to incorrect installation or a lack of understanding of the instructions. Your System One Intercom is fairly comprehensive and as such it may take a little time to familiarize yourself with its operation.

Should you have doubts, do not hesitate to contact your local distributor who is able to provide professional service for all your intercom needs.

TECHNICAL SPECIFICATIONS

Intercom

- Digital Control Circuitry
- Electret Microphones
- Wide Dynamic Range
- Independent Amplification

Speakers

- Cloth Suspension, Single cone 102 mm, 16 Ohm, 10 Watt with 3 ounce magnet

Power requirement

- 13.8V DC Regulated Supply (Current rating dependent on size of system)

NOTES