



Photoelectric Smoke Detector

Models: **2W-B, 2WT-B**
4W-B, 4WT-B



3825 Ohio Avenue, St. Charles, Illinois 60174
1-800-SENSOR2, FAX: 630-377-6495
www.systemsensor.com

Before Installing

Please read thoroughly System Sensor manual A05-1003, *Application Guide: System Smoke Detectors*, which provides detailed information on detector spacing, placement, zoning, wiring, and special applications. Copies of this manual are available from System Sensor at no charge.

NOTICE: This manual shall be left with the owner/user of this equipment.

IMPORTANT: This detector must be tested and maintained regularly following NFPA 72 requirements. At a minimum, cleaning should be performed annually.

General Description

Models 2W-B and 2WT-B are 2-wire photoelectric smoke detectors; models 4W-B and 4WT-B are 4-wire photoelectric smoke detectors. All models incorporate a state-of-the-art optical sensing chamber and an advanced microprocessor. The microprocessor allows the detector to automatically adjust its sensitivity back to the factory setting when it becomes more sensitive due to contaminants settling in its chamber. Should it become necessary, the screen/sensing chamber is field replaceable. Models 2WT-B and 4WT-B also feature a restorable, built-in, fixed temperature (135°F) thermal detector and are also capable of sensing a freeze condition if the temperature is below 41°F.

All i³ Series detectors are designed to provide open area protection. Two-wire models must be used with compatible UL Listed panels only.

When used with an i³ Series compatible control panel or the i³ Series 2W-MOD module (refer to installation manual D500-46-00), the 2W-B and 2WT-B are capable of generating a “maintenance needed” signal. The 2W-MOD can indicate a need for cleaning, replacement, or a freeze condition (2WT-B only) at the control panel or module.

Installation of the 2W-B, 2WT-B, 4W-B, and 4WT-B detectors is simplified by the use of a mounting base that may be pre-wired to the system, allowing the detector to be easily installed or removed. The mounting base installation is further simplified by the incorporation of features compatible with drywall fasteners.

Two LEDs on the detector provide a local visual indication of the detector’s status:

Table 1: Detector LED Modes

	Green LED	Red LED
Power-up	Blink 10 sec	Blink 10 sec
Normal (standby)	Blink 5 sec	—
Out of sensitivity	—	Blink 5 sec
Freeze Trouble	—	Blink 10 sec
Alarm	—	Solid

After an initial power-up delay, the red and green LEDs will blink synchronously once every ten seconds. It will take approximately 80 seconds for the detector to finish the power-up cycle (see Table 2).

Table 2: Power-up Sequence for LED Status Indication*

Condition	Duration
Initial LED Status Indication	80 seconds
Initial LED Status Indication (if excessive electrical noise is present)	4 minutes

*Refer to Electrical Specifications for power up to alarm time.

NOTE: If, during power-up, the detector determines there is excessive electrical noise in the system such as those caused by improper grounding of the system or the conduit, both LEDs will blink for up to 4 minutes before displaying detector status (see Table 2).

After power-up has completed and the detector is functioning normally within its listed sensitivity range, the green LED blinks once every five seconds. If the detector is in need of maintenance because its sensitivity has shifted outside the listed limits, the red LED blinks once every five seconds. When the detector is in the alarm mode, the red LED latches on. The LED indication must not be used in lieu of the tests specified under **Testing**. In a freeze trouble condition, the red LED will blink once every 10 seconds (refer to Table 1).

To measure the detector’s sensitivity, the i³ Series Model SENS-RDR Infrared Sensitivity Reader tool (see Figure 4) should be used.

Models 2W-B and 2WT-B also include an output that allows an optional Model RA400Z Remote Annunciator to be connected.

Mounting

Each i³ Series detector is supplied with a mounting base that can be mounted:

1. To a single gang box, or
2. To a 3½-inch or 4-inch octagonal box, or
3. To a 4-inch square box with a plaster ring, or
4. Direct mount or to ceiling using drywall fasteners (Figure 2).

Figure 1: Mounting of Detector

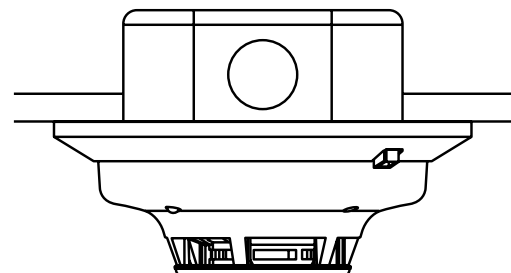

A78-2706-00

The i³ Series heads and bases are keyed so that a 2-wire head will only mount to a 2-wire base, and a 4-wire head will only mount to a 4-wire base. The heads and bases are clearly identified as either 2-wire or 4-wire. When mounting the i³ Series, ensure that the head is mounted to the correct base.

Tamper-Resistant Feature

The i³ Series detectors include a tamper-resistant feature that prevents removal from the mounting base without the use of a tool. To engage the tamper-resistant feature, cut the small plastic tab located on the mounting base (Figure 2), and then install the detector. To remove the detector from the base once it has been made tamper resistant, use a small screwdriver to depress the square tamper release tab, located on the skirt of the mounting base, and turn the detector counterclockwise.

Figure 2: Tamper-Resistant Feature

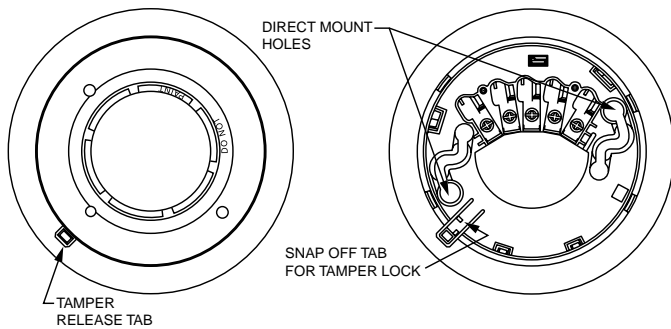

A78-2711-00

Do NOT Install Detectors in the Following Areas:

- In or near areas where particles of combustion are normally present such as kitchens; in garages (vehicle exhaust); near furnaces, hot water heaters, or gas space heaters.
- In very cold or very hot areas.
- In wet or excessively humid areas, or next to bathrooms with showers.
- In dusty, dirty, or insect-infested areas.
- Near fresh air inlets or returns or excessively drafty areas. Air conditioners, heaters, fans, and fresh air intakes and returns can drive smoke away from the detector.

Consult NFPA 72, the local Authority Having Jurisdiction (AHJ), and/or applicable codes for specific information regarding the spacing and placement of smoke detectors.

Wiring Installation Guidelines

All wiring must be installed in compliance with the National Electrical Code, applicable state and local codes, and any special requirements of the local Authority Having Jurisdiction.

Proper wire gauges should be used. The conductors used to connect smoke detectors to the alarm control panel and accessory devices should be color-coded to reduce the likelihood of wiring errors. Improper connections can prevent a system from responding properly in the event of a fire.

The screw terminals in the mounting base will accept 14–22 gauge wire. For best system performance, all wiring should be installed in separate grounded conduit; do not mix fire alarm system wiring in the same conduit as any other electrical wiring. Twisted pair may be used to provide additional protection against extraneous electrical interference.

Wire connections are made by stripping approximately ¼-inch of insulation from the end of the feed wire, inserting it into the proper base terminal, and tightening the screw to secure the wire in place.

Two-Wire Compatibility

System Sensor two-wire smoke detectors are marked with a compatibility identifier located on the label on the back of the product. For two-wire models 2W-B and 2WT-B, connect detectors only to compatible alarm control panels as identified by System Sensor's compatibility chart. This chart contains the current list of detectors and UL Listed compatible control units. A copy of this list is available from System Sensor upon request.

Wiring Diagrams

Figure 3a: Wiring Diagram, 2W-B and 2WT-B

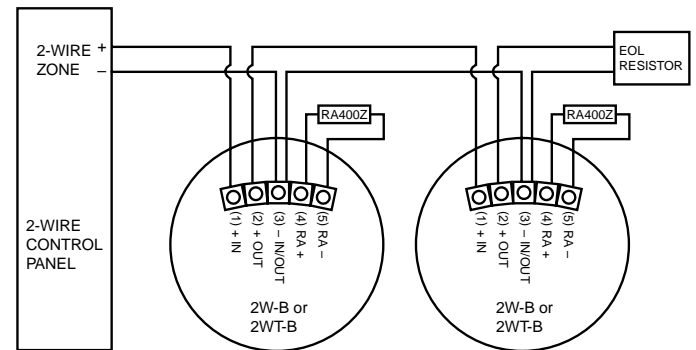

A78-2714-00

Figure 3b: Wiring Diagram, 4W-B and 4WT-B

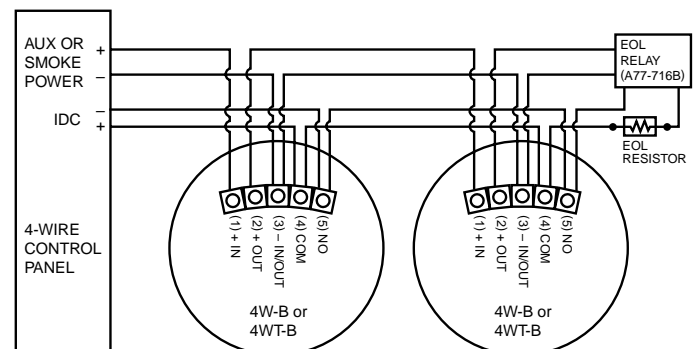

A78-2715-00

Installation



Remove power from alarm control unit or initiating device circuits before installing detectors.

NOTE: To install units so that corresponding LEDs are lined up, refer to the “Green LED” indicator on the base.

1. Wire the mounting base screw terminals per Figure 3a or Figure 3b, as applicable.
2. Place detector on the base and rotate clockwise. The detector will drop into the base and lock into place with a “click”.
3. After all detectors have been installed, apply power to the alarm control unit.
4. Test each detector as described in **Testing**.
5. Reset all the detectors at the alarm control unit.
6. Notify the proper authorities that the system is in operation.

CAUTION

Dust covers are an effective way to limit the entry of dust into the smoke detector sensing chamber. However, they may not completely prevent airborne dust particles from entering the detector. Therefore, System Sensor recommends the removal of detectors before beginning construction or other dust producing activity. When returning the system to service, be sure to remove the dust covers from any detectors that were left in place during construction.

Testing

Detectors must be tested after installation and following maintenance.

NOTE: Before testing, notify the proper authorities that maintenance is being performed and the system will be temporarily out of service. Disable the zone or system undergoing maintenance to prevent any unwanted alarms.

Ensure proper wiring and power is applied. *After power up, allow 80 seconds for the detector to stabilize before testing.*

Test i³ Series detectors as follows:

A. Test Switch

1. An opening for the recessed test switch is located on the detector housing (See Figure 4).
2. Insert a small screwdriver or allen wrench (0.18" max.) into the test switch opening; push and hold.
3. If the detector is within the listed sensitivity limits, the detector's red LED should light within five seconds.

Figure 4: Recessed Test Switch Opening and SENS-RDR Position

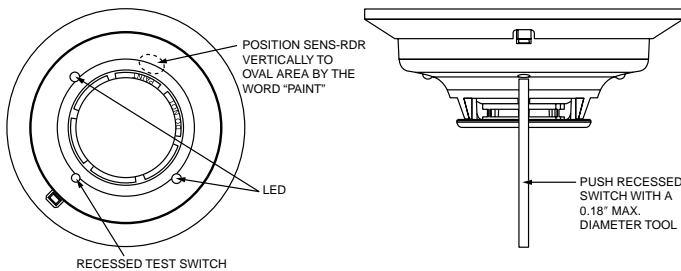

A78-2712-00

B. Smoke Entry Test

Hold a smoldering punk stick or cotton wick at the side of the detector and gently blow the smoke through the detector until it alarms.

C. Direct Heat Method (models 2WT-B and 4WT-B only)

Using a 1000-1500 watt hair dryer, direct the heat toward either of the thermistors. Hold the heat source about 12 inches from the detector to avoid damage to the plastic.

NOTE: For the above tests, the detector will reset only after the power source has been momentarily interrupted.

If a detector fails any of the above test methods, its wiring should be checked and it should be cleaned as outlined in the **Maintenance** section. If the detector still fails, it should be replaced.

Notify the proper authorities when the system is back in service.

Loop Verification (models 2W-B and 2WT-B only)

Loop verification is provided by the EZ Walk loop test feature. This feature is for use with i³ Series compatible control panels or the i³ Series 2W-MOD module only. The EZ Walk loop test verifies the initiating loop wiring and provides visual status indication at each detector.

1. Ensure proper wiring and power is applied. Wait approximately six minutes before performing EZ Walk test.
2. Place control panel or module in EZ Walk Test mode (refer to panel manufacturer's manual or 2W-MOD manual D500-46-00).
3. Observe the LEDs on each detector:

Table 3: EZ Walk Test Detector Modes

	Green LED	Red LED
Proper Operation	Double blink 5 sec	—
Out of Sensitivity	—	Double Blink 5 sec
Freeze Condition	—	Double Blink 10 sec

NOTE: The EZ Walk loop test must not be used instead of alarm testing.

Maintenance

NOTE: Before performing maintenance on the detector, notify the proper authorities that maintenance is being performed and the system will be temporarily out of service. Disable the zone or system undergoing maintenance to prevent any unwanted alarms.

1. Remove the detector cover by turning counterclockwise. (See Figure 5.)
2. Vacuum the cover or use canned air to remove any dust or debris.
3. Remove the top half of the screen/sensing chamber by lifting straight up (Figure 5).
4. Vacuum or use canned air to remove any dust or particles that are present on both chamber halves.
5. Replace the top half of the screen/sensing chamber by aligning the arrow on the screen/sensing chamber with the arrow on the housing. Press down firmly until the screen/sensing chamber is fully seated.
6. Replace the detector cover by placing it over the screen/sensing chamber and turning it clockwise until it snaps into place.
7. Reinstall the detector and test. (See the **Testing** section.)
8. Notify the proper authorities when the system is back in service.

Figure 5: Removing/Replacing Screen/Sensing Chamber

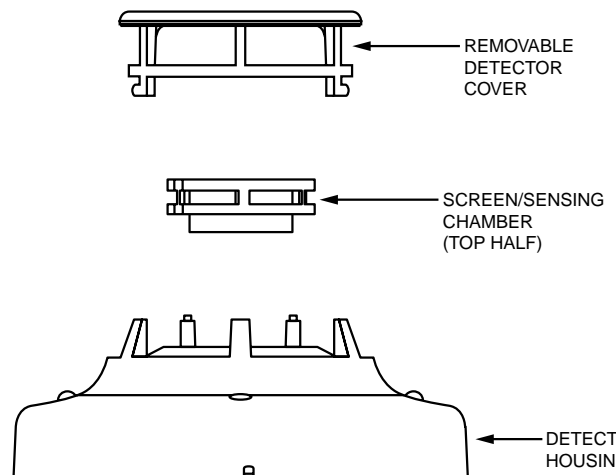

A78-2713-00

Electrical Specifications	2-wire	4-wire	
System Voltage – Nominal:	12/24	12/24	Volts Non-polarized
Min.:	8.5	8.5	Volts
Max.:	35	35	Volts
Max. Ripple Voltage:	30	30	% of nominal peak to peak
Max. Standby Current:	50	50	μ A average
Peak Standby Current:	100	—	μ A
Max. Start-up Capacitance:	0.1	—	μ F
Latching Alarm:	Reset by momentary power interruption		
Maximum Initial Start-up Time:	45	15	sec
Power-up Time after 10 sec. reset:	15	15	sec
Max. Alarm Current:	130	20	mA 12 Volt Systems
(For 2W-B and 2WT-B, panel must limit current)	130	23	mA 24 Volt Systems
Alarm Contact Ratings:	—	0.5	Amp @ 30 V AC/DC
Alarm Reset Voltage:	2.5	2.5	Volts
Alarm Reset Time:	0.3	0.3	sec

Physical Specifications	
Heat Sensor	(Model 2WT-B and 4WT-B): 135°F (57.2°C)
Freeze Trouble	(Model 2WT-B and 4WT-B): 41°F (5°C)
Operating Temperature Range:	2W-B and 4W-B: 32 to 120°F (0 to 49°C)
	2WT-B and 4WT-B: 32 to 100°F (0 to 37.8°C)
Operating Humidity Range:	0 to 95% RH non-condensing
Storage Temperature Range:	-4 to 158°F (-20 to 70°C)
Diameter (including base):	5.3 inches
Height (including base):	2.0 inches
Weight:	6.3 oz.

Please refer to insert for the Limitations of Fire Alarm Systems

Three-Year Limited Warranty

System Sensor warrants its enclosed smoke detector to be free from defects in materials and workmanship under normal use and service for a period of three years from date of manufacture. System Sensor makes no other express warranty for this smoke detector. No agent, representative, dealer, or employee of the Company has the authority to increase or alter the obligations or limitations of this Warranty. The Company's obligation of this Warranty shall be limited to the repair or replacement of any part of the smoke detector which is found to be defective in materials or workmanship under normal use and service during the three year period commencing with the date of manufacture. After phoning System Sensor's toll free number 800-SENSOR2 (736-7672) for a Return Authorization number, send defective units postage prepaid to: System Sensor,

Repair Department, RA #_____, 3825 Ohio Avenue, St. Charles, IL 60174. Please include a note describing the malfunction and suspected cause of failure. The Company shall not be obligated to repair or replace units which are found to be defective because of damage, unreasonable use, modifications, or alterations occurring after the date of manufacture. In no case shall the Company be liable for any consequential or incidental damages for breach of this or any other Warranty, expressed or implied whatsoever, even if the loss or damage is caused by the Company's negligence or fault. Some states do not allow the exclusion or limitation of incidental or consequential damages, so the above limitation or exclusion may not apply to you. This Warranty gives you specific legal rights, and you may also have other rights which vary from state to state.

FCC Statement

This device complies with part 15 of the FCC Rules. Operation is subject to the following two conditions: (1) This device may not cause harmful interference, and (2) this device must accept any interference received, including interference that may cause undesired operation.

Note: This equipment has been tested and found to comply with the limits for a Class B digital device, pursuant to Part 15 of the FCC Rules. These limits are designed to provide reasonable protection against harmful interference in a residential installation. This equipment generates, uses and can radiate radio frequency energy and, if not installed and used in accordance with the instructions, may cause harmful interference to radio communications. However, there is no guarantee that interference will not occur in a particular installation. If this equipment does cause harmful interference to radio or television reception, which can be determined by turning the equipment off and on, the user is encouraged to try to correct the interference by one or more of the following measures:

- Reorient or relocate the receiving antenna.
- Increase the separation between the equipment and receiver.
- Connect the equipment into an outlet on a circuit different from that to which the receiver is connected.
- Consult the dealer or an experienced radio/TV technician for help.